



nextThermal®
smart heat management

Nextflex® Tubular Heaters

www.nextthermal.com

**Next Generation
Flexible Tubular Heaters**

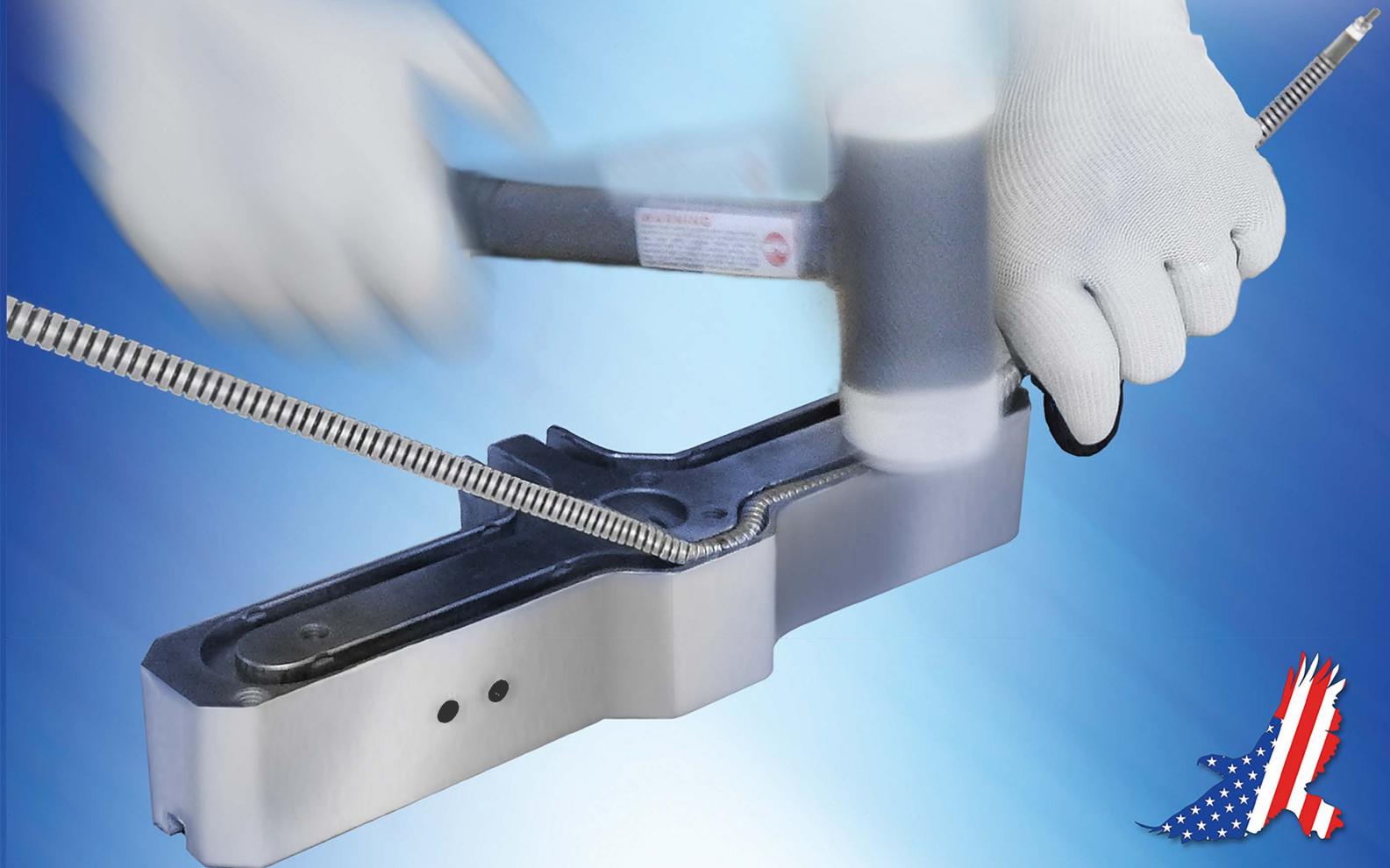

Made in the U.S.A.

The Nextflex® Advantage

- **User Formable – Heavy-Duty Design**

Nextflex's robust design is engineered with a flexible solid casing that stays in the groove, yet is easy to install.

- **Optimized Durability**

Nextflex is engineered with an inner layer of highly compressed copper powder, giving Nextflex increased durability while maintaining flexibility.

- **Same Day Shipping**

Ships in simple-to-install straight lengths the same day for orders placed before 2 p.m. Eastern Standard Time.

- **Marked at Center and Cold Sections**

Nextflex is conveniently marked at both the center and the cold sections for visual verification during installation.

- **Technical Support**

Nextthermal can assist you in selection, installation advice, and improving application performance.

- **Made in the USA**

Nextthermal products are manufactured in the United States in Battle Creek, Mich.

- **The New Standard in Flexible Tubular Heaters!**

Made in the USA, Versatile Nextflex replaces formed tubular heaters for optimized thermal transfer and improved process performance.

- Plastic Injection Molding
- Rubber Molding
- Packaging
- Plastic Welding
- Plate Heating
- Specialty heated tools
- Food Processing Market

Thermal image demonstrating the heating efficiency of the Nextflex tubular heater placed within a manifold.

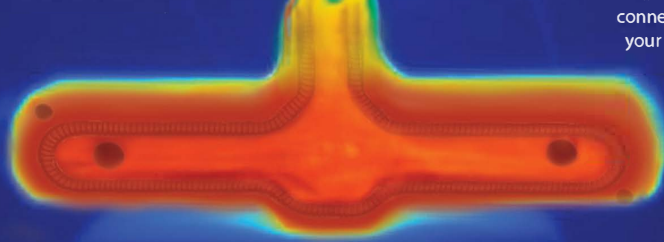

Nextthermal can add custom connections to your Nextflex.



Groove Dimensions for Nextflex

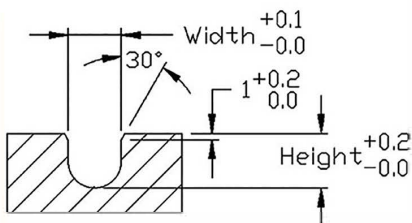

In MM	Width	Height
Ø6.5	6.0	6.4
Ø8.0	7.65	7.9
Ø8.5	8.15	8.4

Technical Specifications

Minimum Bending Radius (Inside)	Ø8.0/Ø8.5 mm = R10 mm Ø6.5 mm = R 6.5 mm
Maximum Temperature	371 °C (700 °F)
High Volt Stability	1000 VAC
Insulation Resistance	> = 5M @ 500 VDC
Leakage Current	< = 0.5mA @ 253 VAC
Wattage Tolerance	±10%
Max Voltage	250 VAC
Diameter Tolerance	Nominal Ø ± 0.10 mm
Length Tolerance	±1.5%

Nextflex Stocking List

Decoding
Nextflex Part
Numbers



Length	Heated Length	06.5 ±0.1 mm Diameter (230V), M2.5 Connection		8.0 mm ±0.1 Diameter (240V), M4 Connection		8.5 mm ±0.1 Diameter (230V), M4 Connection	
		Part Number	Wattage	Part Number	Wattage	Part Number	Wattage
300 mm	240 mm	65R-0300	350W	80R-0300 ●	560W	85R-0300	650W
350 mm	290 mm	65R-0350	400W	80R-0350 ●	675W	85R-0350	750W
400 mm	340 mm	65R-0400 ●	500W	80R-0400 ●	795W	85R-0400	900W
425 mm	365 mm	—	—	80R-0425 ●	850W	85R-0425	975W
450 mm	390 mm	65R-0450 ●	600W	80R-0450 ●	910W	85R-0450	1050W
475 mm	415 mm	—	—	80R-0475 ●	970W	85R-0475	1100W
500 mm	440 mm	65R-0500 ●	650W	80R-0500 ●	1025W	85R-0500 ●	1150W
525 mm	465 mm	—	—	80R-0525 ●	1090W	85R-0525 ●	1225W
550 mm	490 mm	65R-0550 ●	700W	80R-0550 ●	1145W	85R-0550 ●	1300W
575 mm	515 mm	—	—	80R-0575 ●	1200W	85R-0575 ●	1375W
600 mm	540 mm	65R-0600 ●	800W	80R-0600 ●	1260W	85R-0600 ●	1450W
625 mm	565 mm	—	—	80R-0625 ●	1320W	85R-0625 ●	1525W
650 mm	590 mm	65R-0650 ●	850W	80R-0650 ●	1380W	85R-0650 ●	1600W
675 mm	—	—	—	80R-0675 ●	1440W	85R-0675	1675W
700 mm	640 mm	65R-0700 ●	900W	80R-0700 ●	1495W	85R-0700 ●	1750W
725 mm	—	—	—	80R-0725 ●	1550W	85R-0725	1825W
750 mm	690 mm	65R-0750 ●	1000W	80R-0750 ●	1615W	85R-0750 ●	1900W
775 mm	—	—	—	80R-0775 ●	1670W	85R-0775	1975W
800 mm	740 mm	65R-0800 ●	1100W	80R-0800 ●	1730W	85R-0800 ●	2050W
850 mm	790 mm	65R-0850	1200W	80R-0850 ●	1845W	85R-0850 ●	2200W
900 mm	840 mm	65R-0900	1300W	80R-0900 ●	1960W	85R-0900 ●	2350W
950 mm	890 mm	65R-0950	1350W	80R-0950 ●	2080W	85R-0950 ●	2500W
1000 mm	940 mm	65R-1000	1400W	80R-1000 ●	2195W	85R-1000 ●	2650W
1050 mm	990 mm	65R-1050	1450W	80R-1050 ●	2316W	85R-1050 ●	2800W
1100 mm	1040 mm	65R-1100	1500W	80R-1100 ●	2430W	85R-1100 ●	2930W
1150 mm	1090 mm	65R-1150	1550W	80R-1150 ●	2545W	85R-1150 ●	3060W
1200 mm	1140 mm	65R-1200	1600W	80R-1200 ●	2665W	85R-1200 ●	3190W
1250 mm	1190 mm	65R-1250	1650W	80R-1250 ●	2780W	85R-1250 ●	3320W
1300 mm	1240 mm	65R-1300	1700W	80R-1300 ●	2895W	85R-1300 ●	3450W
1350 mm	1290 mm	65R-1350	1800W	80R-1350 ●	3015W	85R-1350 ●	3580W
1400 mm	1340 mm	65R-1400	1900W	80R-1400 ●	3130W	85R-1400 ●	3600W
1450 mm	1390 mm	65R-1450	2000W	80R-1450 ●	3245W	85R-1450 ●	3600W
1500 mm	1440 mm	65R-1500	2100W	80R-1500 ●	3365W	85R-1500 ●	3600W
1550 mm	1490 mm	—	—	80R-1550 ●	3480W	—	—
1600 mm	1540 mm	—	—	80R-1600 ●	3600W	—	—
1650 mm	1590 mm	—	—	80R-1650 ●	3600W	—	—
1700 mm	1640 mm	—	—	80R-1700 ●	3600W	—	—
1750 mm	1690 mm	—	—	80R-1750 ●	3600W	—	—
1800 mm	1740 mm	—	—	80R-1800 ●	3600W	—	—
1850 mm	1790 mm	—	—	80R-1850 ●	3600W	—	—
1900 mm	1840 mm	—	—	80R-1900 ●	3600W	—	—
1950 mm	1890 mm	—	—	80R-1950 ●	3600W	—	—
2000 mm	1940 mm	—	—	80R-2000 ●	3600W	—	—
2050 mm	1990 mm	—	—	80R-2050 ●	3600W	—	—
2100 mm	2040 mm	—	—	80R-2100 ●	3600W	—	—

● Sizes available for same-day shipping on orders placed by 2 p.m. EST.

To convert metric values to imperial, divide by 25.4
Example:
500 / 25.4 = 19.685"

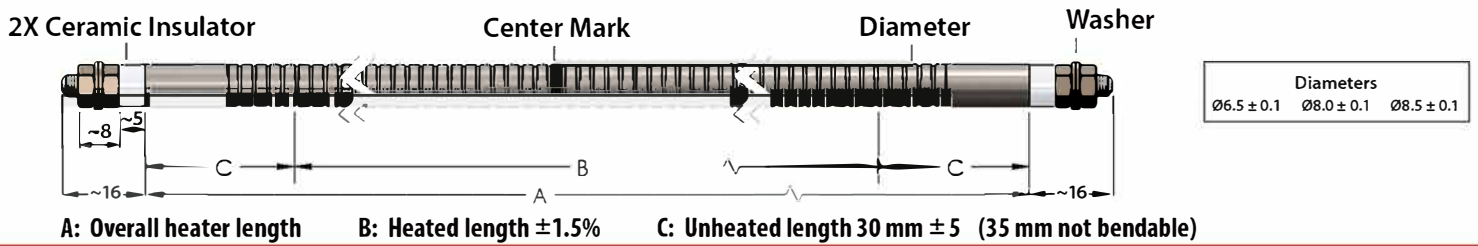

Ordering the Right Nextflex Heater for Your Application.

Because Nextflex expands when installed in manifolds with bends, you will need to calculate the correct Nextflex straight length. Proper length depends on how many bends in the heated path your manifold has, and their radiuses. Addressing expansion in your heater will prevent heated sections from sticking out past the manifold and shortening heater life. Below, in Figure 1, is an example manifold with the straight lengths marked in red. Bend groups are marked in green, blue and orange.

Step 1: Identify and measure the straight lengths.

Using the example manifold in Figure 1, you will see that there are seven straight lengths. Since these do not expand, your equation should look like this:
(60 mm x 4) + (25 mm x 2) + 20 mm = 310 mm (Total Straight Length)

Step 2: Identify the bends and measure their radiuses.

Group length of the bends with the same radius and add them together. For example, using the manifold in Figure 1, you have 10 radiuses. Two of these are R10 radiuses. Using the following formula, $Length = 2 \times \pi \times R \times C / 360$, (where R = bend radius, and C = bend degrees), your equation will look like this:

- I. $2 \times 3.14 \times 10 \text{ mm (R10 bend radius)} \times (180/360) = 31.4 \text{ mm (length of one bend)}$
- II. $31.4 \text{ mm} + 31.4 \text{ mm} = 62.8 \text{ mm (total length of both R10 bends)}$

Step 3: Adjust bended sections for Nextflex expansion.

To adjust for expansion, you will need to identify the diameter of your manifold groove (see Figure 2). Find the column for the radius length you measured in Step 2, and then multiply by the corresponding decimal. If we continue with the example from Step 2 using the two R10 bends and assume your groove diameter is 8 mm, the Expansion Chart shows your expansion factor multiplier is 0.92. Given this information, this is what your equation will look like:

62.8 mm (total length of R10 radiuses) x 0.92 = 57.78 mm (adjusted total length of the R10 group of radiuses)

Repeat this process for each bend group identified in your manifold.

Step 4: Add straight lengths (from Step 1) with all adjusted bend lengths (from Step 3)

Once you have the adjusted lengths for all your bends, simply add them together. Using the identified bends in Figure 1 as an example, your equation will look like this:

$$310 \text{ mm (total straight lengths)} + 57.776 \text{ mm (R10)} + 97.39 \text{ mm (R12.5)} + 118.1 \text{ mm (R15)} = 583.266 \text{ (adjusted heater length)}$$

Step 5: Identify the correct Nextflex part number.

In the example above, the total heater length is 583.266 mm. Rounding up to the next Nextflex size, the correct Nextflex length is a 600 mm heater, Part Number 80R-0600. Following these instructions, you can be assured you will not have heated sections sticking out of your manifold.

NOTE: If your total adjusted heater length is less than 10 mm from the next size up heater part number, you will need to move up two sizes in length from your calculated value. For example: Your adjusted calculated heater length is 648 mm. You should select the 675 mm heater instead of the 650 mm.

An online calculator to help you identify the correct Nextflex part number is available at www.nextthermal.com.

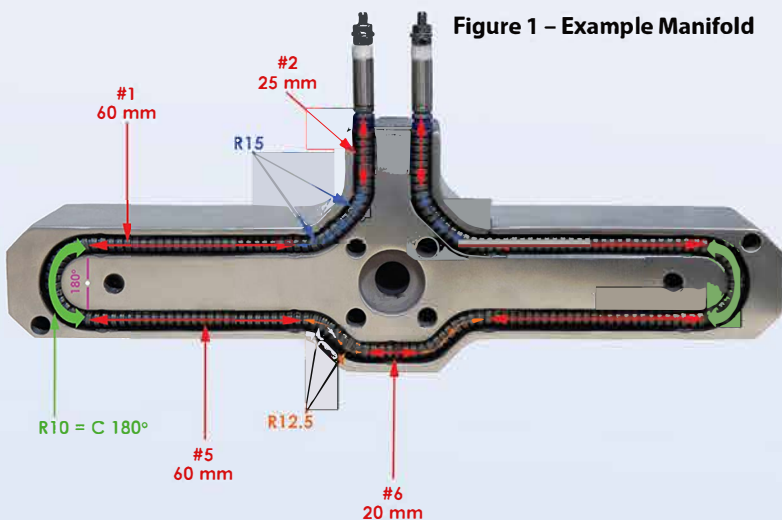

Nextflex Best Practices

- Expansion factors in the chart below are subject to change. Please reference www.nextthermal.com for the most updated factors.
- Always use a hard Nylon® hammer when forming into the groove to avoid deforming the casing.
- Install the last 35 mm of unheated Nextflex sections straight. Do not bend unheated section sticking outside of the manifold.
- Cover plate or retaining clips are recommended to hold heater in place for best results and heat transfer.
- All installations must be electrically grounded.
- Heated lengths must be within the manifold groove.
- See Page 5 of this brochure for Installation Instructions. Visit www.nextthermal.com to view the Installation Video.

Figure 2 - Expansion Factors Chart

Diameter	R 10	R 12.5	R 15	> R 15
6.5 mm	0.83	0.85	0.88	0.92
8 mm	0.92	0.93	0.94	0.96
8.5 mm	0.94	0.95	0.95	0.96

Do This Online!

Access the Nextflex Length & Part Number Calculator at www.nextthermal.com.

Nextflex® Heater Installation

Measurement Prep (These steps can be skipped if you already have the center of the manifold groove marked.)



Measurement 1
Press a cord into the manifold groove (a 16-2 extension cord works well).



Measurement 2
Mark the location of the groove starting and ending points on the cord.

Note: Because the heater length will grow during installation, consult the expansion chart on page 2 to ensure proper heater selection.

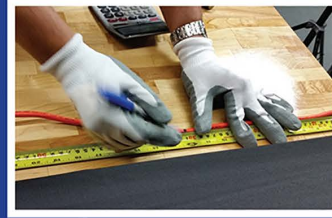

Measurement 3
Measure the length between the two marks and make a third mark at the center point.



Measurement 4
Press the cord back in the groove, starting with one groove end line at the end of the manifold groove. Install to the center point of the groove and mark the center point on the manifold. You are now ready to install the Nextflex.

Installation Instructions



Step 1
Starting at the center of the groove, bend the Nextflex heater at the center mark consistent with the direction of the groove.



Step 2
Hold the Nextflex heater directly above the groove at the point of installation. Strike the Nextflex heater hard to seat it well. Form and install in short lengths to prevent rebending. Always start by installing the heater at the center mark at the center location of the groove.



Step 3
It is important to make sure the Nextflex heater is directly above the groove prior to striking. Form and install in 1 to 2 inch sections (25 to 50 mm).
NOTE: Heater is flexible due to annealing. Multiple bends in the same location "work harden" the heater. For best results, form the heater as precisely as possible prior to installing in the groove.



Step 4
Keeping the heater flat and forming it with your free hand, bend bends so that it is directly above the groove.
IMPORTANT: Make sure the straight section of the groove is fully installed prior to forming your bend.



Step 5
One strong strike is more effective than two soft strikes. If your groove dimensions are correct, you will not damage the internal heater.



Step 6
The Nextflex staking tool is a key component in seating the heater properly. This improves heat transfer and maximizes heater life. Strike hard to stake every 3/4 inch \approx 20 mm.

Nexthermal World Headquarters

www.nexthermal.com

1045 Harts Lake Road • Battle Creek, MI, U.S.A. 49037
Main: +1-269-964-0271
Fax: +1-269-964-4526

sales@nexthermal.com



MMSDC

Michigan Minority Supplier
Development Council



Applications



Thermally optimize packaging machines to improve seals, decrease scrap and maximize product throughput.

Participated in the Olympics in testing for controlled substances and for creating snow.

Enabled mass spectrometry systems to detect parts per billion.

Extend the capabilities of existing hot runner injection molding designs and assist new product development.

Designed assemblies to improve food production cycle time, hygienic design and capacity.

Helped make disease detection of Malaria, Bird Flu, and more than 2,000 other diseases faster, more affordable and portable.

Created energy savings opportunities for food production companies.

nexthermal

*Imagine what we can do when we
combine experience and innovate together.*

